

Features

- Low reverse leakage
- High forward surge capability
- High reliability
- Ultrafast recovery time for high efficiency
- High temperature soldering guaranteed: 260°C/10seconds, 9.5mm lead length
- Lead and body according with RoHS standard

Mechanical Data

Case: DO-27 Molded plastic

Terminals: Plated axial leads, solderable per MIL-STD-750, Method 2026

Polarity: Color band denotes cathode end

Mounting Position: Any

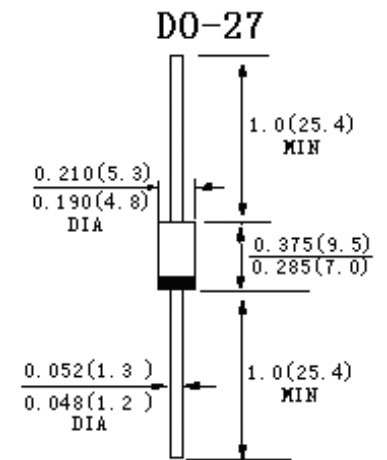

Dimensions in inches and (millimeters)

Maximum Ratings and Electrical Characteristics

Rating at 25°C ambient temperature unless otherwise specified

Single phase, half wave, 60 Hz, resistive or inductive load

For capacitive load, derate current by 20%

TYPE NUMBER	Symbols	SF31	SF32	SF34	SF36	SF37	SF38	Units
Maximum repetitive peak reverse voltage	V_{RRM}	50	100	200	400	500	600	V
Maximum RMS voltage	V_{RMS}	35	70	140	280	350	420	V
Maximum DC blocking voltage	V_{DC}	50	100	200	400	500	600	V
Maximum average forward rectified current 9.5mm lead length at $T_A=55^\circ\text{C}$	$I_{F(AV)}$	3.0						A
Peak Forward Surge Current, 8.3ms single half-wave superimposed on rated load (JEDEC method)	I_{FSM}	150						A
Maximum instantaneous forward voltage at 3.0A	V_F	0.95		1.25	1.7		V	
Maximum reverse recovery time (Note: 1)	T_{rr}	35						nS
Maximum DC reverse current at rated DC blocking voltage	$T_a=25^\circ\text{C}$	I_{R1}						μA
	$T_a=100^\circ\text{C}$	I_{R2}						μA
Operating junction temperature range	T_J	-55to+150						$^\circ\text{C}$
Storage temperature range	T_{stg}	-55to+150						$^\circ\text{C}$

Note: 1. Reverse Recovery Test Conditions: $I_F=0.5\text{A}$, $I_R=1.0\text{A}$, $I_{RR}=0.25\text{A}$.

Characteristic Curves

Fig. 1 - Forward Current Derating Curve

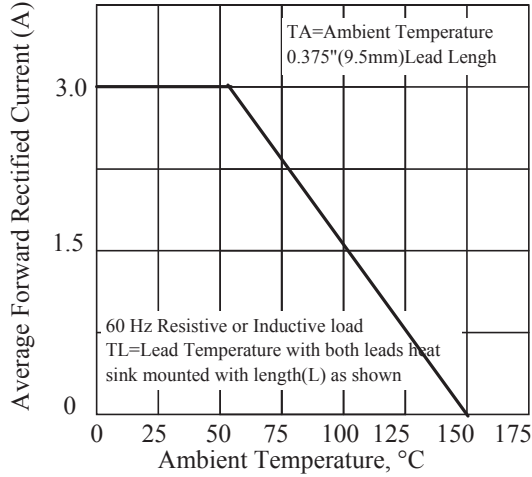

Fig. 2 - Maximum Non-repetitive Peak Forward Surge Current

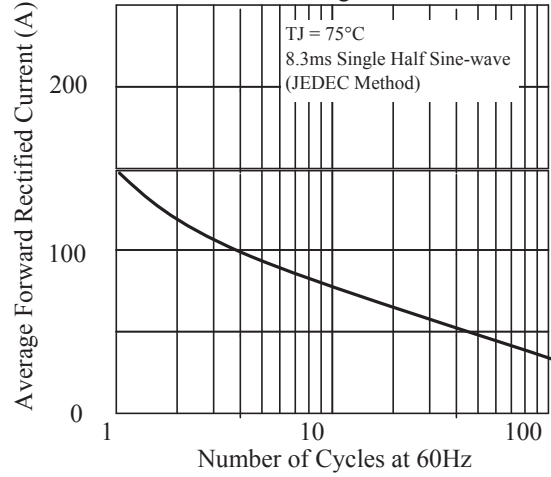

Fig 3. - Typical Instantaneous Forward Characteristics

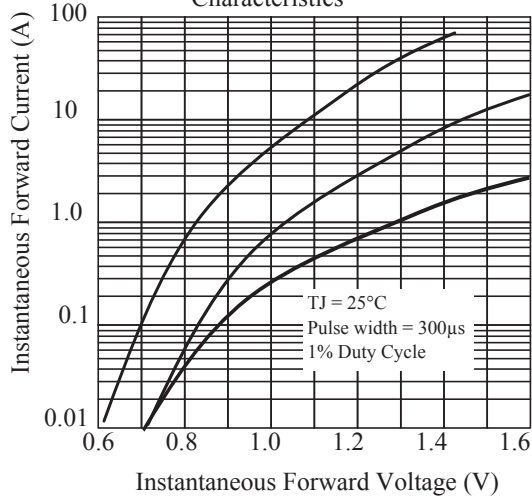

Fig 4. - Typical Reverse Characteristics

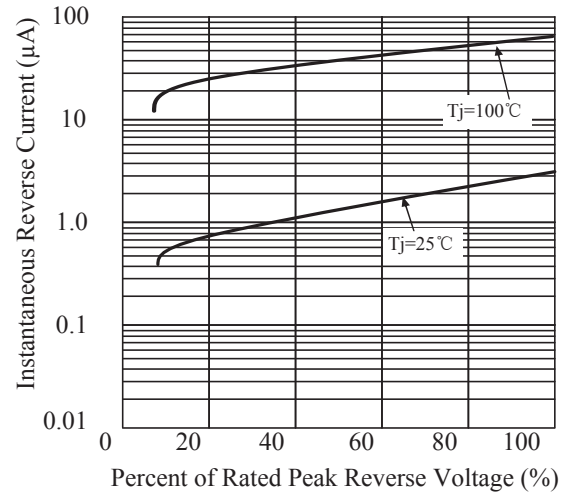

Fig 5. - typical Junction Capacitance

